

Watchman® Series WC
Cast Iron Receiver
Single or Duplex

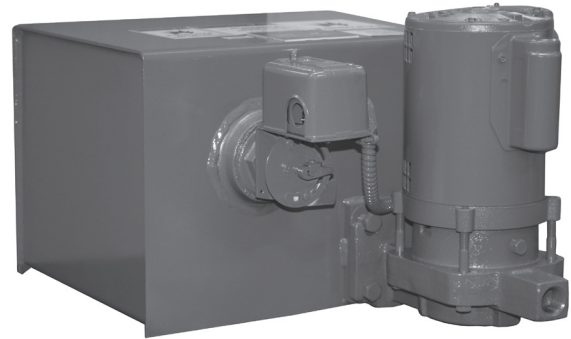

Watchman® Series WCS
Steel Receiver
Single or Duplex

Hoffman Specialty Watchman® Series WC® & WCS® Condensate Units Replacement Parts



Bell & Gossett

a xylem brand

Index

How To Use This Parts List	3
Identifying Your Watchman Unit	4-7
Pump Parts for “B” Style Pump	8
Pump Parts for “A” Style Pump	8
Float Switches & Mechanical Alternators	9
Receivers, Conduit Assemblies & Misc. Parts	10

How to use this PARTS LIST

The unit nameplate identifies the Watchman unit by its respective unit designation as is shown below.

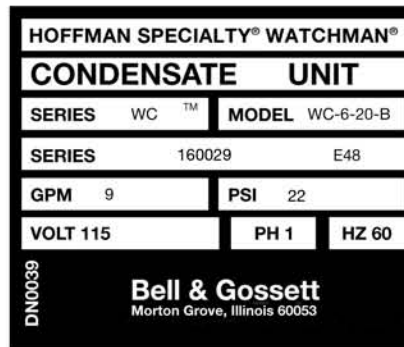

The nameplate identifies the pump in the example above as a Series WC, model number WC 6-20-B. The serial number that is noted on the nameplate corresponds to the Bell & Gossett commodity code number that has appeared on your Domestic/Hoffman price sheets.

Units that have nameplates showing the former Shippensburg, PA address will not refer to commodity codes and should be identified by the physical characteristics of the pumps furnished on the unit.

- All Shippensburg, PA built units were furnished with the “A” Design Receivers. (See Pages 6 and 7.)
- Units manufactured between December 1, 1982 and September 30, 1983 will show the Shippensburg, PA address and were furnished with the “B” Style Pumps and “A” Design Receivers.
- Units manufactured between October 1, 1983 and June 30, 1990 show the Morton Grove, IL address and were furnished with the “B” Style Pumps and “A” Design Receivers.
- Units manufactured after July 1, 1990 were furnished with both the “B” Style Pumps and “B” Design Receivers.

The following procedure is recommended for determining appropriate replacement parts.

1. Determine if the address shown on the nameplate is Shippensburg, PA (all units manufactured 1983 or earlier) or Morton Grove, IL (all units after October 1, 1983).
2. Determine by physical characteristics if the **Pump** is a Packed Construction, “A” Style or “B” Style. Refer to pages 4, 5 & 6 for information regarding how to determine if pump is Packed, “A” or “B” Style.
3. Select items from drawings on pages 6 and 7.
4. Refer to the index to determine appropriate pages for parts information.

Identifying Your Watchman Unit

Due to the fact that the Watchman unit is a factory stocked product, unique serial numbers have not been applied to the product. It is therefore necessary to identify the specific generation of product by the physical characteristics of the pump and of the receiver.

Figure 1 on the following page indicates two types of piping arrangements that have been used for the Watchman. You'll note the Packing Construction and "A" Style Watchman indicates a discharge pipe that is parallel to the receiver face (a 90 degree discharge from the pump suction). The "B" Style is piped perpendicular to the receiver face (a 180 degree or in-line discharge from the pump suction). This only applies to the "A" design receiver configuration.

Figure 2 shows cut-away drawings of all three generations of pumps used on the Watchman. The uniquely identifiable characteristics of each generation is the discharge orientation and the number of capscrews used to hold the volute to the motor (or motor bracket). By using these two easily identifiable characteristics, and referring to the following chart, it is possible to identify the style of pump on the unit.

	Suction to Discharge Orientation	No. of Capscrews
Packed Pump	90	4
"A" Style	90	3
"B" Style	180	4

Figure 3 indicates the parts required to adapt the current "B" Style pump and motor assembly to replace the older design "A" Style pump. Note that the adapter piping is about 1/2" wider than the "A" Style pump and motor discharge position. This can be taken up by use of a short nipple and/or a union in place of the existing discharge piping.

FIGURE 1

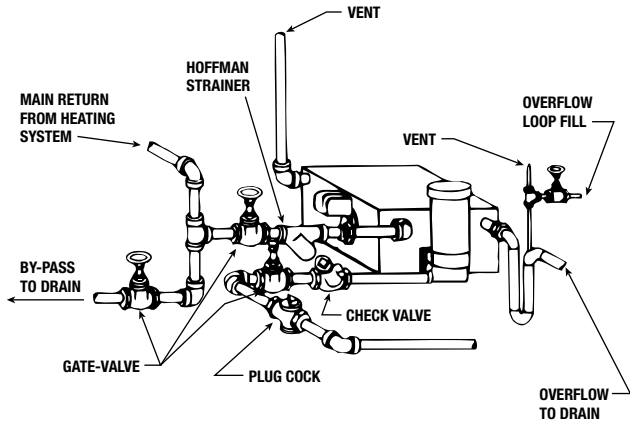

WC PACKED AND "A" STYLE

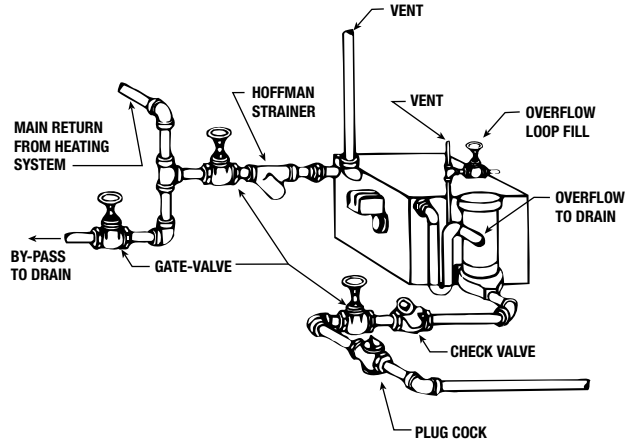

WC "B" STYLE

FIGURE 2

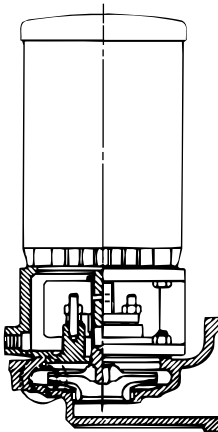

PACKED PUMP

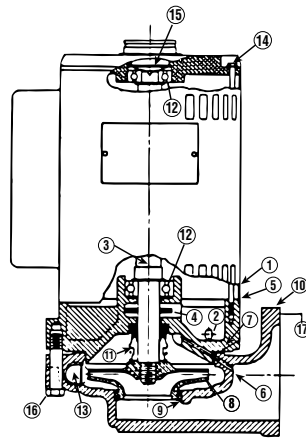

"A" STYLE

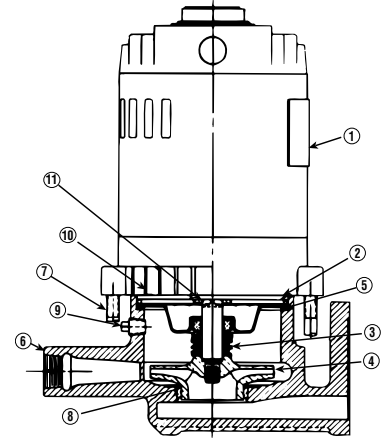

"B" STYLE

FIGURE 3

**Piping Conversion
"B" To "A" Style
Location**

**Items Required To
Adjust Piping**

- (1) 3/4" 90° Street Elbow
- (1) 3/4" X 2" Nipple
- (1) 3/4" 90° Elbow
- (1) 3/4" X 2 1/2" Nipple
- (1) 3/4" 90° Elbow

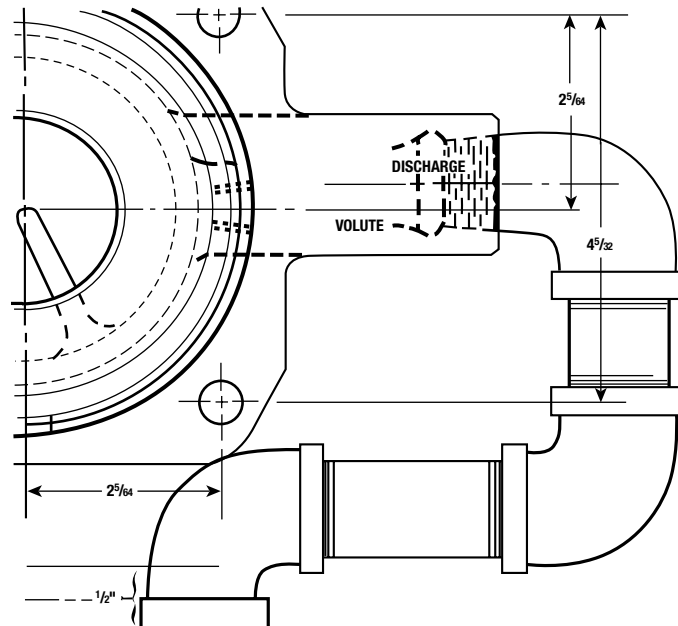

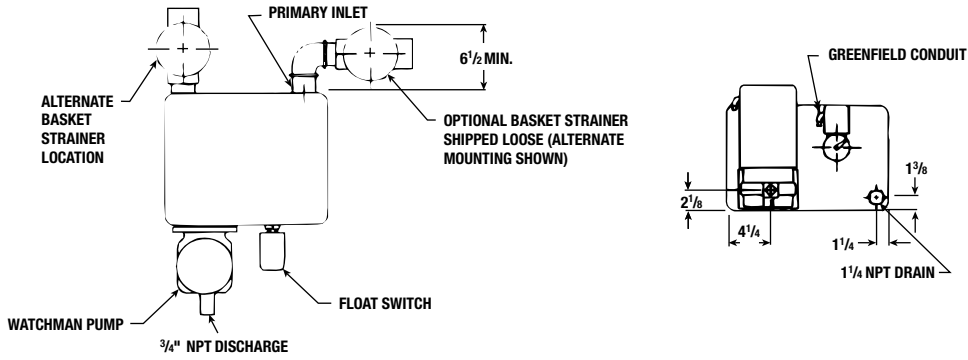

6 & 9 GALLON "B" STYLE PUMP / "B" DESIGN RECEIVER

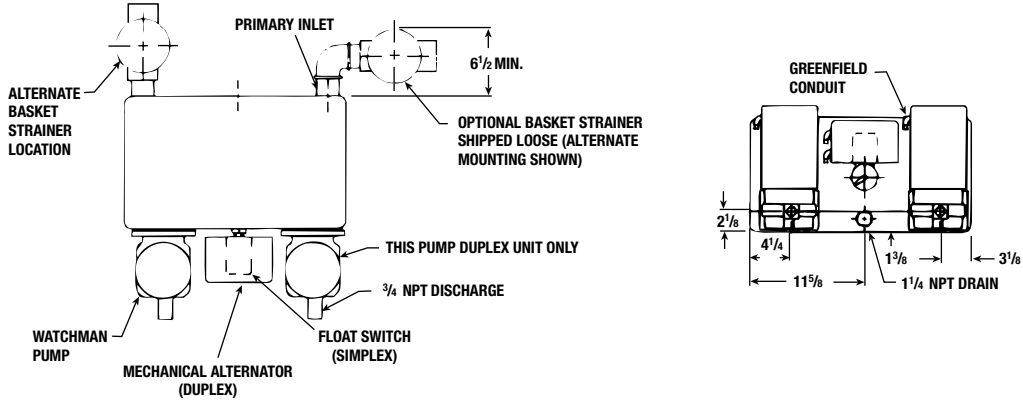

14 GALLON "B" STYLE PUMP / "B" DESIGN RECEIVER

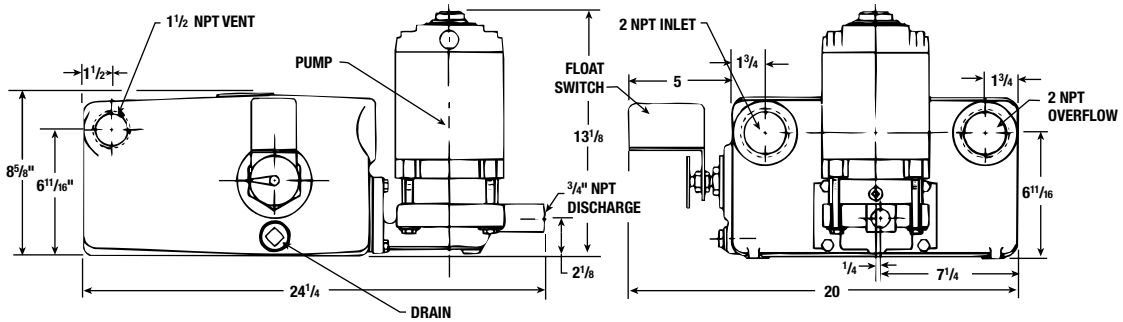

6 GALLON "B" STYLE PUMP / "A" DESIGN RECEIVER

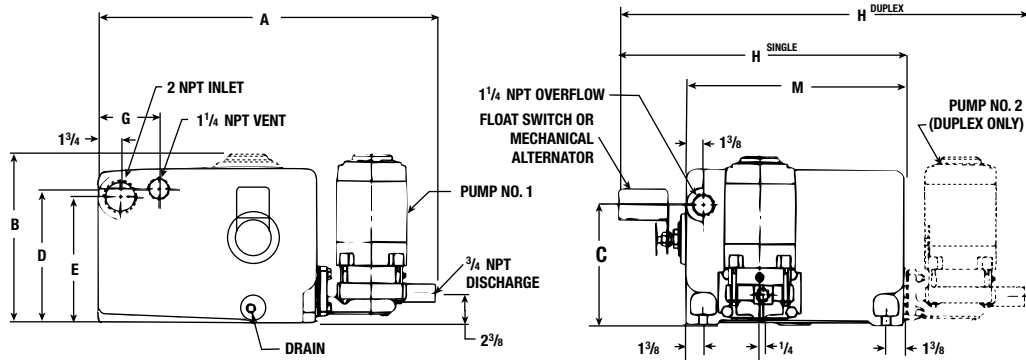

9 & 14 GALLON "B" STYLE PUMP / "A" DESIGN RECEIVER

EDR	STYLE	REC. CAP	A	B	C	D	E	F	G	H	M
8,000	Single	9	24 1/2	13 3/8	8 5/8	9 5/8	9	7 1/2	4 3/4	20 3/4	15
12,000	Single	14	26 3/8	13 3/8	9 1/2	10 1/2	9 7/8	5 3/4	4 3/4	23 13/16	17
12,000	Duplex	14	26 3/8	13 3/8	9 1/2	10 1/2	9 7/8	5 3/4	4 3/4	31 7/8	17

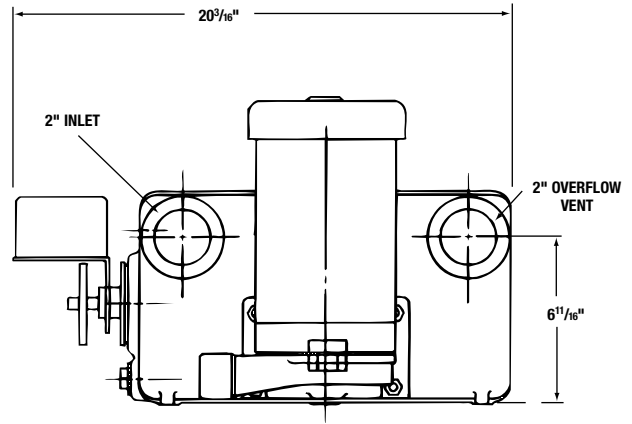
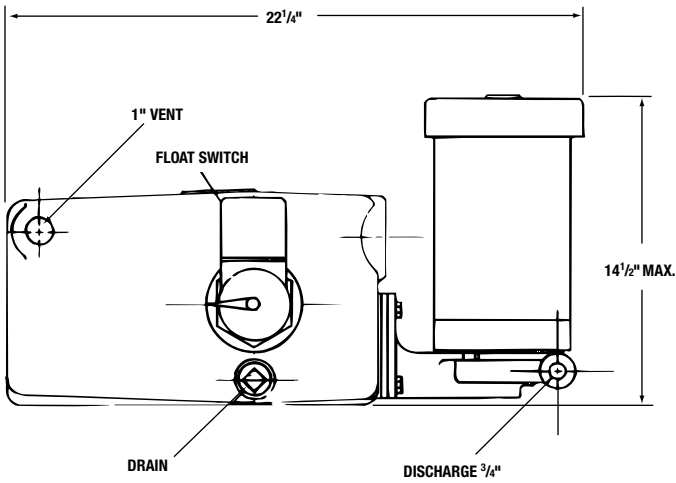

6 GALLON "A" STYLE PUMP / "A" DESIGN RECEIVER

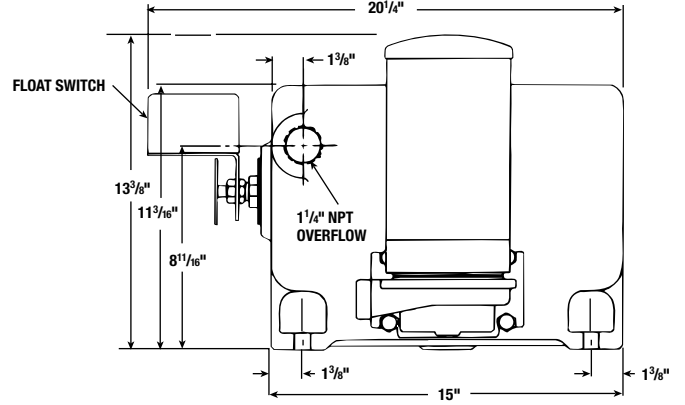
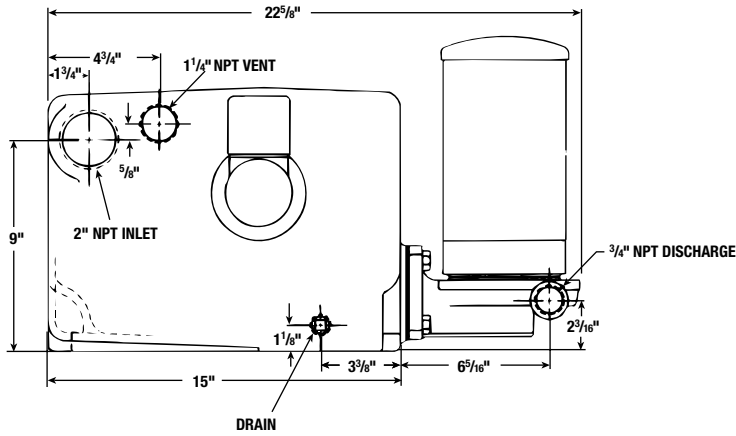

9 & 14 GALLON "A" STYLE PUMP / "A" DESIGN RECEIVER

SQUARE FEET EDR	STYLE	RECEIVER CAPACITY GALLON	DIMENSIONS		
			A	B	C
8,000	Single	9	24	9	8 ⁵ / ₈
8,000	Duplex	14	27	7 ⁷ / ₈	9 ¹ / ₂
12,000	Single	14	27	9 ⁷ / ₈	9 ¹ / ₂
12,000	Duplex	14	27	9 ⁷ / ₈	9 ¹ / ₂

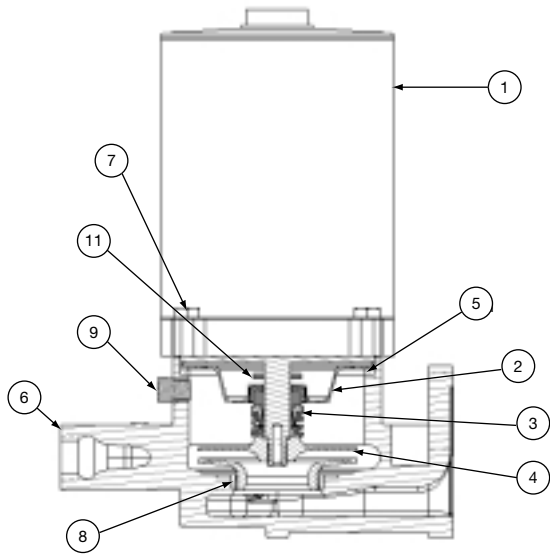

AFTER 2003

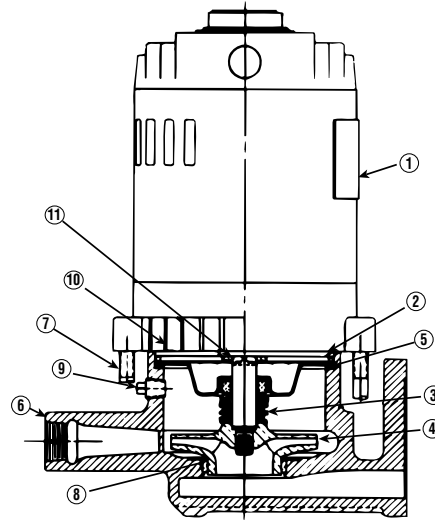

1983-2003

ITEM NUMBER	DESCRIPTION	NUMBER REQUIRED	PUMPS MANUFACTURED BETWEEN 1983 TO 2003	PUMPS MANUFACTURED AFTER 2003
			PART NUMBER	PART NUMBER
1	Motor 1/3 hp, 1 ph, 3500 rpm	1	DM0005	DM0005
2	Seal Holder	1	DP0290	DP1966
3	Seal	1	-	-
4	Impeller	1	DP0321	DP0321
5	Head Gasket	1	DG0092	DG0092
6	Pump Case with Wearing Ring	1	DP1665	DP1665
7	Capscrew	4	DJ0083	DJ0083
8	Wear Ring	1	DP0482	DP0482
9	Pipe Plug 1/4"	1	P39040	P39040
10	Wire Spacer	1	DP0291	-
11	Water Slinger	1	DP0848	DP0848
	Seal Kit including Mechanical Seal, Head Gasket & Case to Receiver Gasket	1	180013	180013
	Complete Pump and Motor Assembly	1	180001	180001

Order Replacement Parts by Description and Part No.
Specify Serial No. shown on nameplate.

WATCHMAN "A" STYLE PUMP AND MOTOR ASSEMBLY

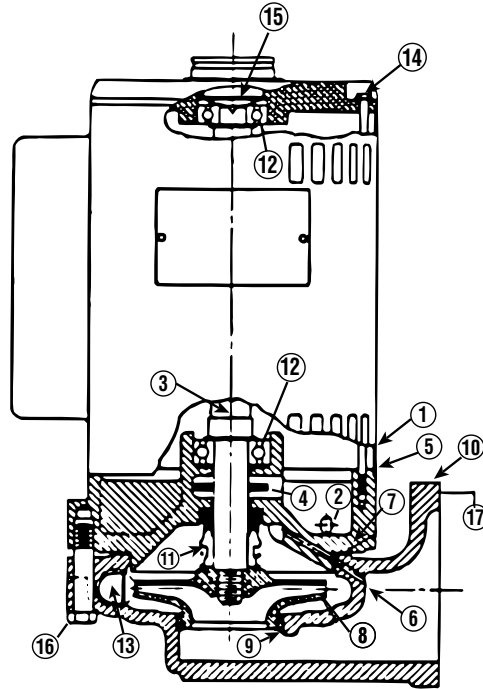

ITEM NUMBER	DESCRIPTION	NUMBER REQUIRED	PART NUMBER
1-5	Motor with Pump Head	1	180061
4	Water Slinger	1	DP0848
5	Pump Head	1	DP0206
7	Head Gasket	1	DG0134
8	Impeller	1	DP0321
9	Case Wearing Ring	1	DP0482
9-10	Pump Case with Wearing Ring	1	DP1602
16	Head to Case Capscrews	3	DJ0077
17	Case to Receiver Gasket	1	DG0060
*	Seal Kit including Mechanical Seal, Head Gasket & Case to Receiver Gasket	1	180013
	Complete Pump and Motor Assembly	1	180060

Order Replacement Parts by Description and Part No.

Specify Serial No. shown on nameplate.

* Seal only. Consult factory.

- Factory recommended spare parts.

FLOAT SWITCH ASSEMBLY

INSTRUCTIONS

APPLICATION – For automatically controlling the liquid level in a closed tank by float movement.

MOUNTING – Screw-in Tank Float Switches are mounted directly to the tank by means of the 2 1/2" I.P.S. threaded fitting (D). Before screwing this fitting into the tank, loosen Nut (C) so that the fitting (D) is free to rotate in the switch bracket. Tighten the fitting (D) so that there will be no leak past the threads. Then revolve the switch case until it is horizontal and tighten Nut (C).

REVERSE ACTION – To change, relocate operating link to the opposite slot in base plate and corresponding hole in adjusting plate.

ADJUSTMENT – Switches are shipped from the factory set for a specified float travel. Reasonable adjustment of float travel can be made in the field by moving adjusting strips (7) which are held in place by Screws (A) and (B). Loosening Screw (B) and moving upper adjusting strip (7) will affect the upper limit of float travel only. Loosening Screw (A) and moving lower adjusting strip (7) will affect the lower limit of float travel.

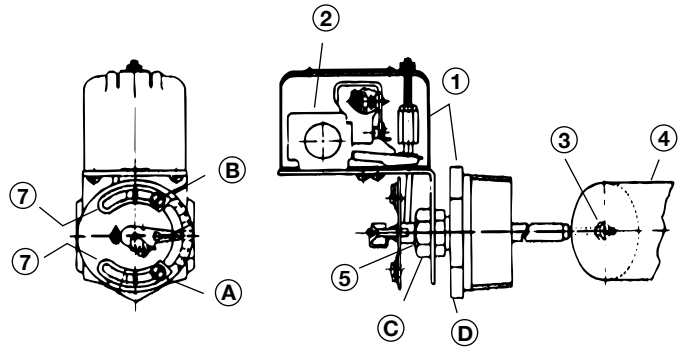

CAUTION: Switches are shipped with a bracket attached to the mounting plate. This bracket prevents the float and the rod from moving in the tank during shipment. When installing the system, this clearly marked shipping bracket must be removed and discarded.

ITEM NUMBER	DESCRIPTION	NUMBER REQUIRED	PART NUMBER
1	Complete Float Switch with Foat – NEMA 1	1	DA0393
4	Float	1	DA0165
*	Float Switch Seal Kit	1	180095

MECHANICAL ALTERNATOR ASSEMBLY

INSTRUCTIONS

APPLICATION – Mechanical alternators serve to open and close an electric circuit by an upward and downward float movement. The forces are applied by means of a float operating between different liquid levels. The action is such that two switch units are alternated on successive cycles. If the liquid level continues to rise or fall with one pump in operation, the lever will continue to travel to a further position at which point the "second" switch will be operated, throwing the stand-by pump across the line.

MOUNTING – Mechanical alternators are mounted directly to the tank by means of the 2 1/2" I.P.S. threaded fitting (D). Before screwing this fitting into the tank, loosen Nut (C) so that the fitting (D) is free to rotate in the switch bracket. Tighten the fitting (D) so that there will be no leak past the threads. Then revolve the switch case until it is horizontal and tighten Nut (C).

STANDARD OPERATION – Contacts are arranged for sump action. In this form the contacts will close on increase in liquid level.

REVERSE ACTION – To change, relocate operating link to the opposite slot in base plate and corresponding hole in adjusting plate.

ADJUSTMENT – Switches are shipped from the factory set for a specified float travel. Reasonable adjustment of float travel can be made in the field by moving adjusting strips (7) which

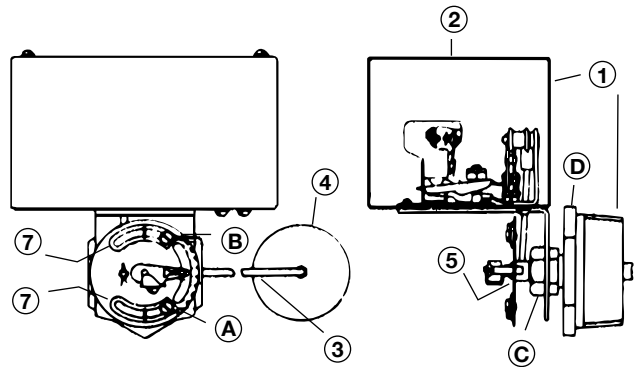

are held in place by Screws (A) and (B). Loosening Screw (B) and moving upper adjusting strip (7) will affect the upper limit of float travel only. Loosening Screw (A) and moving lower adjusting strip (7) will affect the lower limit of float travel.

CAUTION: Switches are shipped with a bracket attached to the mounting plate. This bracket prevents the float and the rod from moving in the tank during shipment. When installing the system, this clearly marked shipping bracket must be removed and discarded.

ITEM NUMBER	DESCRIPTION	NUMBER REQUIRED	PART NUMBER
1	Complete Mech. Altr. with Foat – NEMA 1	1	DA0361
4	Float	1	DA0165
*	Float Switch Seal Kit	1	180095

REPRESENTATIVE WIRING DIAGRAMS

WATCHMAN® SIMPLEX UNITS, SINGLE PHASE

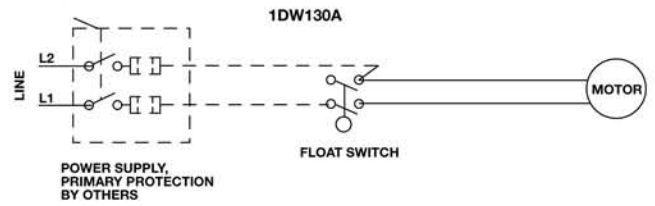
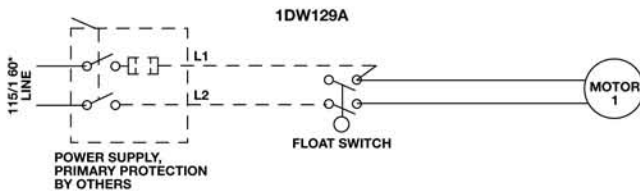

WATCHMAN® AND SCC1 DUPLEX UNITS, SINGLE PHASE

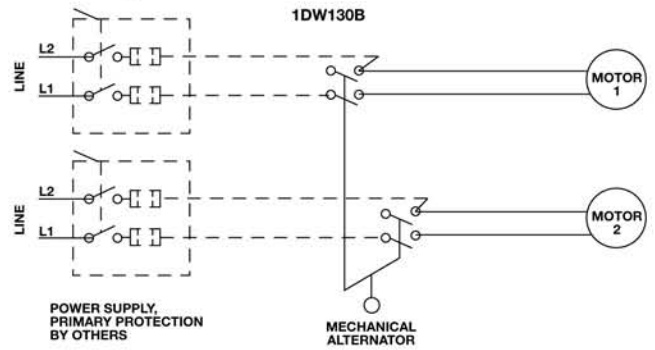
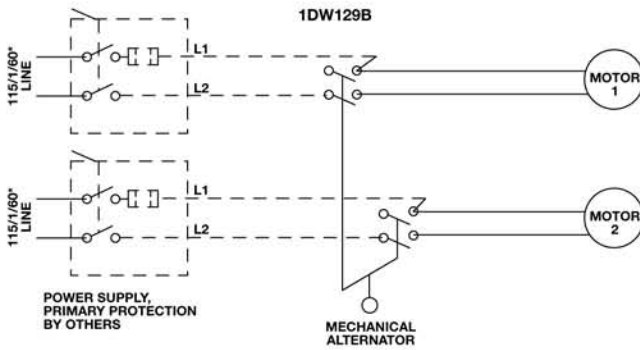

FIELD WIRING SHOULD BE IN ACCORDANCE WITH NATIONAL ELECTRIC CODE.
DASHED LINE WIRING & COMPONENTS BY OTHERS

*230/1/60 VOLTAGE PERMISSIBLE IF MOTOR IS RECONNECTED PER 'HIGH VOLTAGE' DIAGRAM ON MOTOR AND APPLICABLE PRIMARY PROTECTION IS SUPPLIED.

RECEIVERS

SIZE	PART NUMBER
6 Gallon B	DR0610
9 Gallon B	DR0612
14 Gallon B	DR0614
6 Gallon B Steel	DT0766
9 Gallon B Steel	DT0769
14 Gallon B Steel	DT0772
6 Gallon A	DR0202
9 Gallon A	DR0206
14 Gallon A Simplex	DR0216
14 Gallon A Duplex	DR0214

 - Factory recommended spare parts.

CONDUIT ASSEMBLIES

6 Gallon B	DE0084
9 Gallon B	DE0084
14 Gallon B	DE0084
6 Gallon A	DE0802
9 Gallon A	DE0802
14 Gallon A Simplex	DE0802
14 Gallon A Duplex	DE0802 & DE0804

MISCELLANEOUS PARTS

Blind Flange	DF0210
Gasket	DG0060
Mounting Capscrews (4)	DJ0113

WCD30-30 B MA

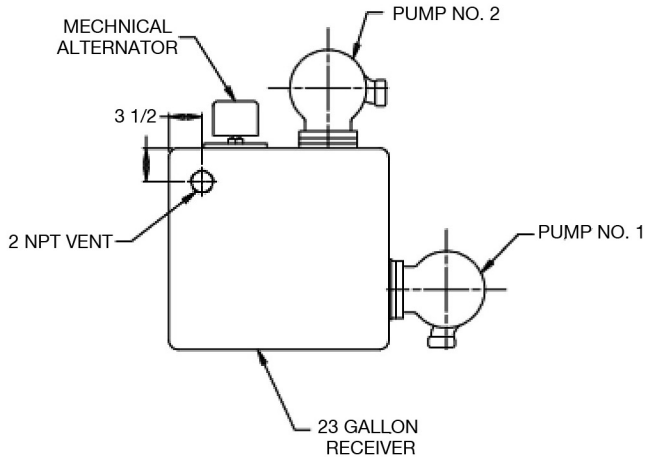

RECEIVER CAPACITY:
GROSS 23 GALLONS
NET 16 GALLONS

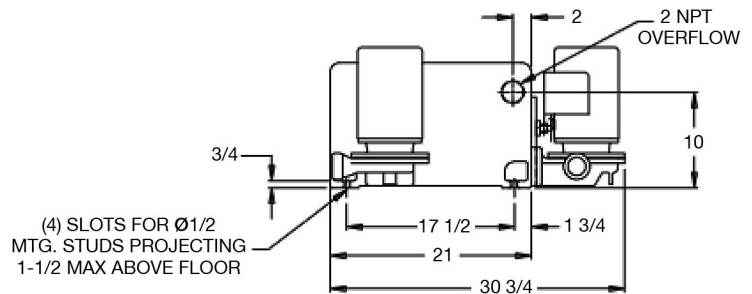
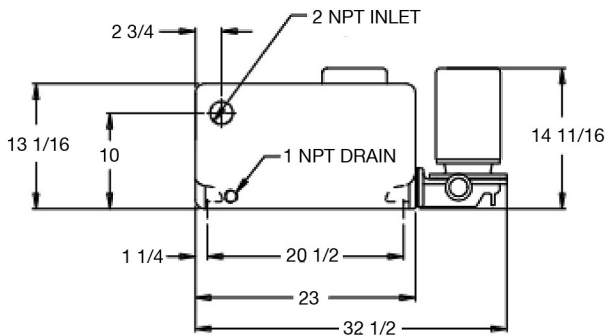
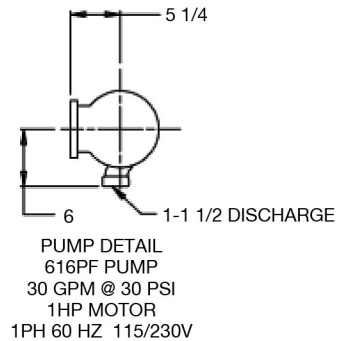

Pump and Motor Assembly 180027

Description	Part Number	Quantity
Motor	DM0055	1
Impeller	DP0336	1
Pump Head/Motor Bracket	DP0208	1
Wearing Ring	DP0482	1
Impeller Capscrew	DJ0213	1
Impeller Washer	DJ0267	1
Capscrews	DJ0066	8
Water Slinger	DP0848	1
Seal and Gasket Kit	180014	1

Description	Part Number	Quantity
Pump to receiver gasket	DG0060	2
Plug	F08400	1
Plug	U19200	1
Hex Nut	F11400	8
Mechanical Alternator	DA0361	1
Pump mounting studs	DJ0479	8
Receiver	DR0218	1
Hex Nut	F11400	8
Plug 2-1/2 "	F12200	1
Plug 1/2"	H47900	1
Plug 1/2"	H47900	2
Conduit Assembly	DE1878	1
Conduit Assembly	DE0084	1
Pump and motor Assembly	180027	2

We value your feedback. Please take our 3 question survey at bellgossett.com/survey to let us know how we are doing.



Xylem Inc.
8200 N. Austin Avenue
Morton Grove, Illinois 60053
Phone: (847) 966-3700
Fax: (847) 965-8379
www.bellgossett.com

Bell & Gossett is a trademark of Xylem Inc. or one of its subsidiaries.
© 2016 Xylem Inc. DN0436D November 2016