

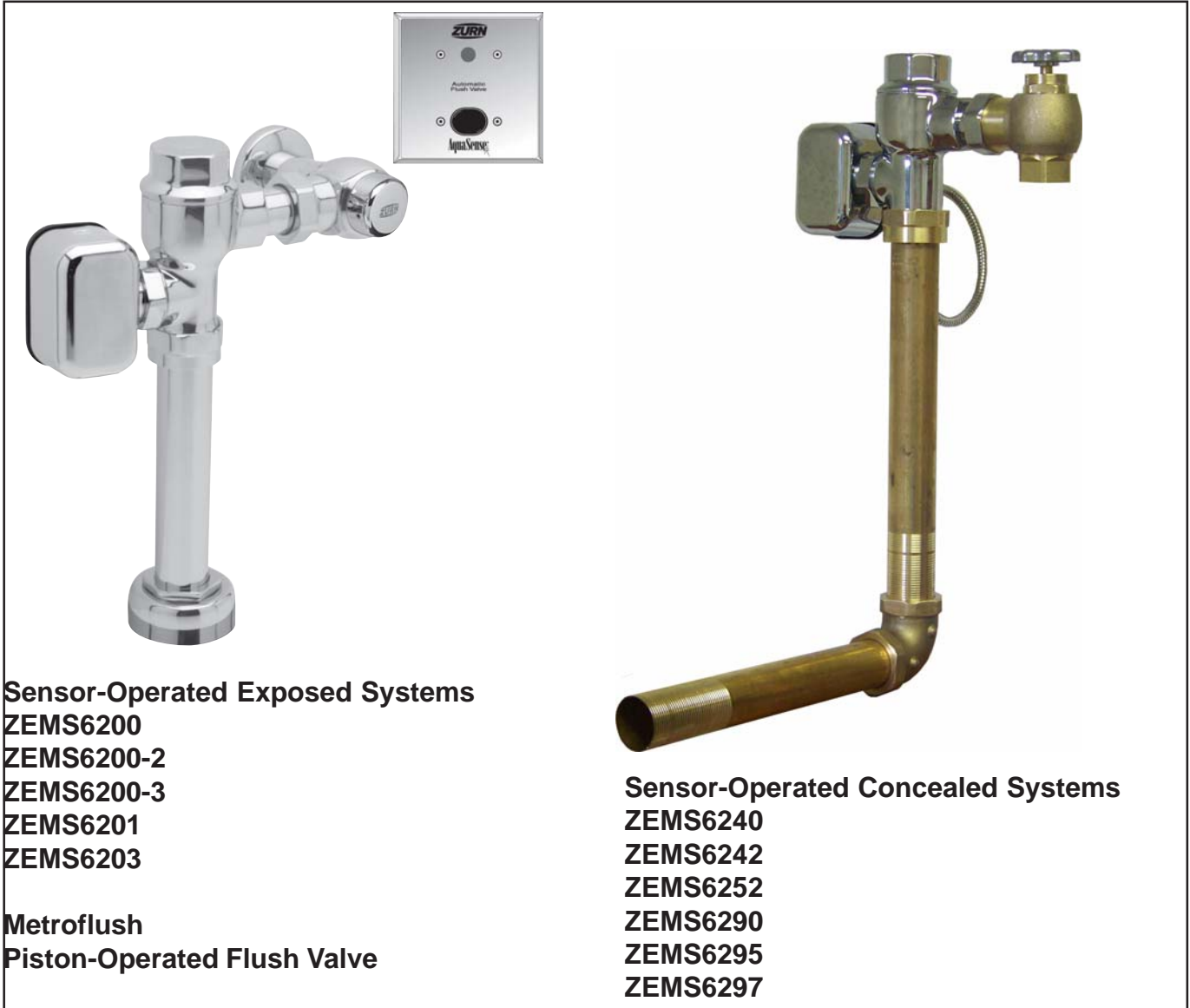

# AquaSense® Metroflush® ZEMS Series

Automatic Systems Sensor-Operated  
AquaVantage Flushometer  
Installation, Operation,  
Maintenance and Parts Manual  
Patented and Patents Pending



### Sensor-Operated Exposed Systems

- ZEMS6200
- ZEMS6200-2
- ZEMS6200-3
- ZEMS6201
- ZEMS6203

Metroflush  
Piston-Operated Flush Valve

### Sensor-Operated Concealed Systems

- ZEMS6240
- ZEMS6242
- ZEMS6252
- ZEMS6290
- ZEMS6295
- ZEMS6297

### LIMITED WARRANTY

All goods sold hereunder are warranted to be free from defects in material and factory workmanship for a period of five years from the date of purchase. Decorative finishes warranted for one year. We will replace at no costs goods that prove defective provided we are notified in writing of such defect and the goods are returned to us prepaid at Sanford, NC, with evidence that they have been properly maintained and used in accordance with instructions. We shall not be responsible for any labor charges or any loss, injury or damages whatsoever, including incidental or consequential damages. The sole and exclusive remedy shall be limited to the replacement of the defective goods. Before installation and use, the purchaser shall determine the suitability of the product for his intended use and the purchaser assumes all risk and liability whatever in connection therewith. Where permitted by law, the implied warranty of merchantability is expressly excluded. If the products sold hereunder are "consumer products," the implied warranty of merchantability is limited to a period of three years and shall be limited solely to the replacement of the defective goods. All weights stated in our catalogs and lists are approximate and are not guaranteed.

# Valve Rough-In

**Model ZEMS6200**

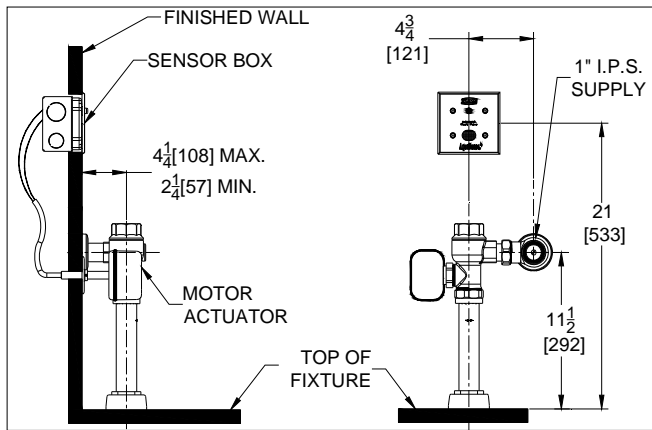

**Models ZEMS6200-2 and ZEMS6200-3**

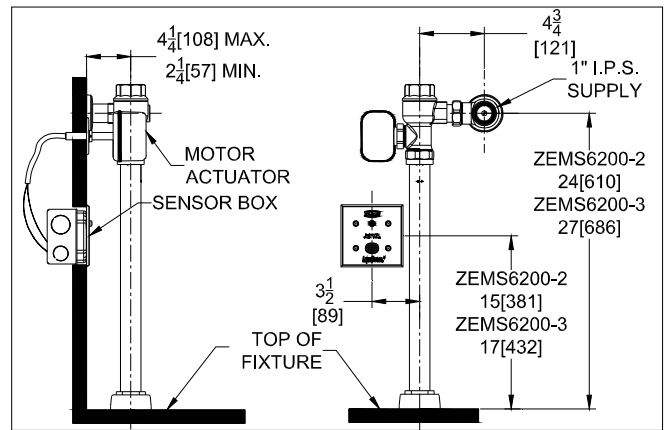

**Model ZEMS6240**

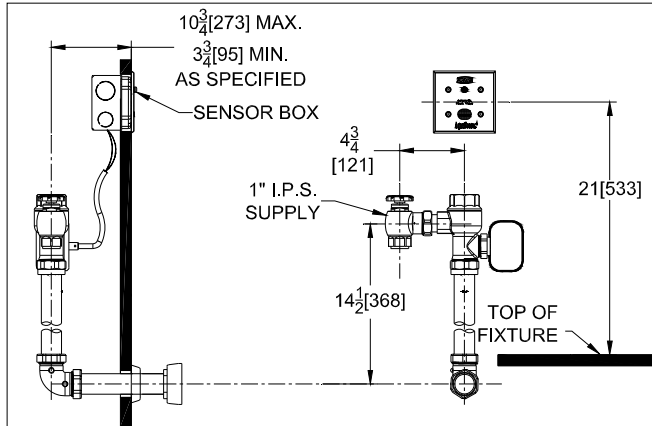

**Model ZEMS6242**

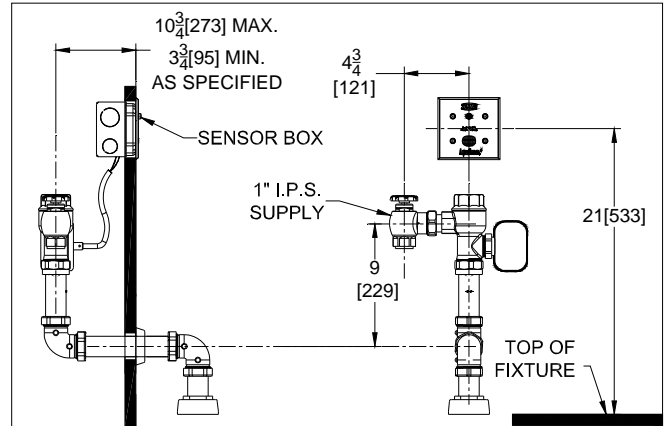

**Model ZEMS6252**

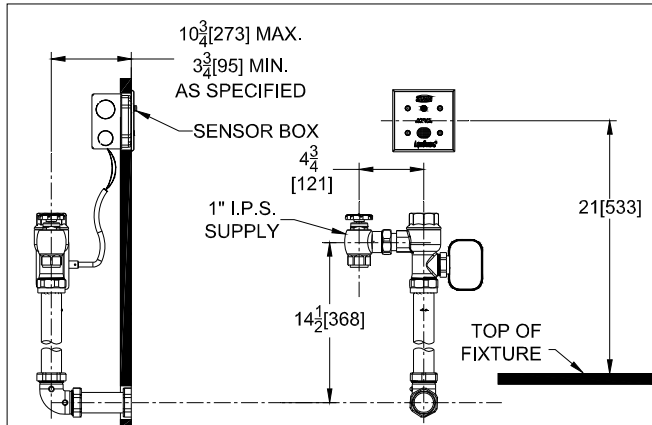

**Models ZEMS6201 and ZEMS6203**

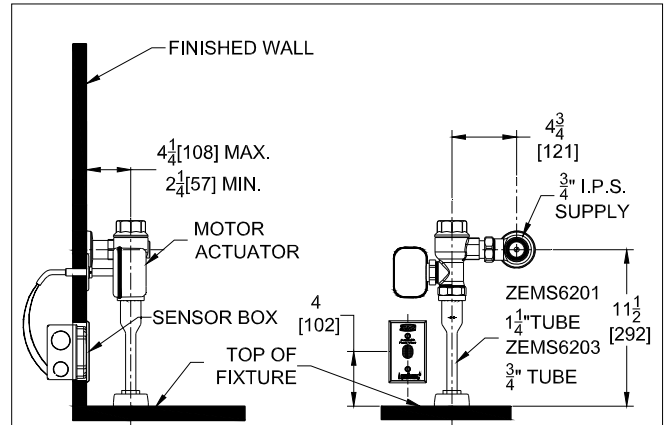

**Model ZEMS6290**

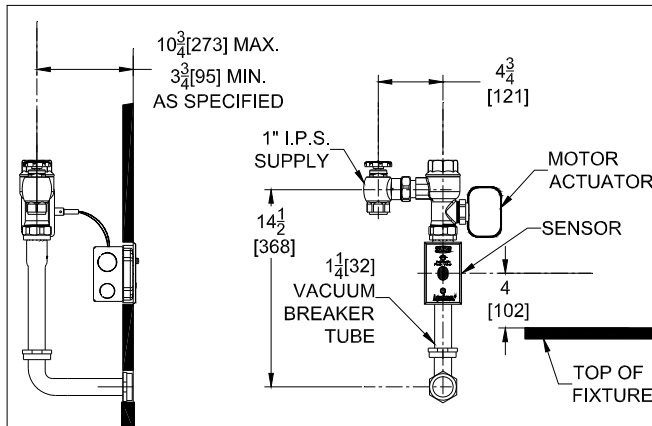

**Model ZEMS6295**

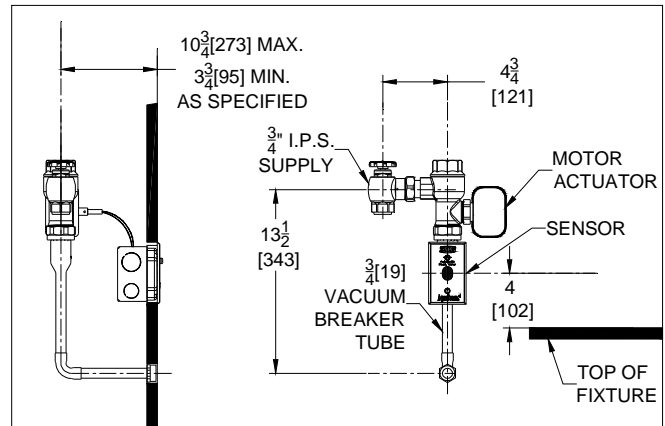

## Model ZEMS6297

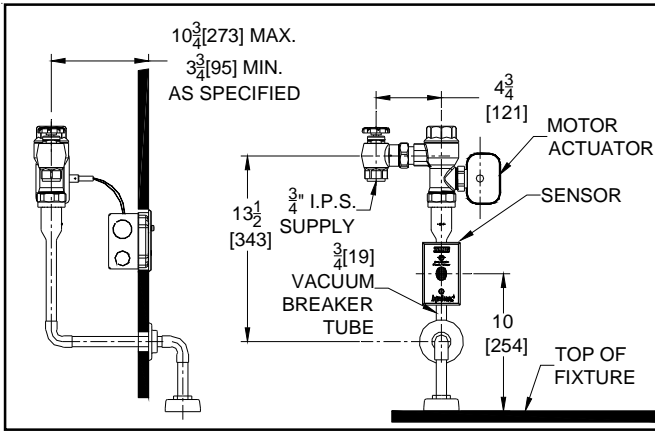

### IMPORTANT:

- All electrical wiring is to be installed in accordance with National/Local codes and regulations.
- All plumbing is to be installed in accordance with applicable codes and regulations.
- Water supply lines must be sized to provide an adequate volume of water for each fixture.
- Flush all water lines prior to making connections.
- Sensor units should not be located across from each other or in close proximity to highly reflective surfaces.
- Control Stop should never be opened to allow flow greater than fixture is capable of evacuating. In the event of valve failure, fixture must be able to handle a continuous flow.

## Electrical

### AC/DC Power Supply

Install hardwired power supply or receptacle for the Zurn Power Converter in a convenient location. An optional mini junction box (P6000-MJ) is recommended to distribute power to each sensor location. It is also recommended that brown wire be used for the DC positive (+) of the supply and blue wire be used for the DC negative (-) of the supply. This matches the sensor and actuator wire colors.

**NOTE:** One Zurn P6000-HW6 or P6000-PC6 Power Converter can operate as many as eight Automatic Sensor equipped Flushometers. The Power Converter is supplied with a six-foot cord. If additional wire is needed from the Power Converter to the Flushometer(s), use #18 AWG for this (by others). **Do not supply power** to the Power Converter until installation of actuator, sensor and Flushometer is completed and checked. **Proper polarity must be observed or damage to one or all components will result.**

### Electrical Hook-up (Figure 1)

Be certain power is off to prevent damage to electrical components. Connect the sensor to the actuator and power converter exactly as shown in Figure 1.

**Double check that power converter polarity is correct.**

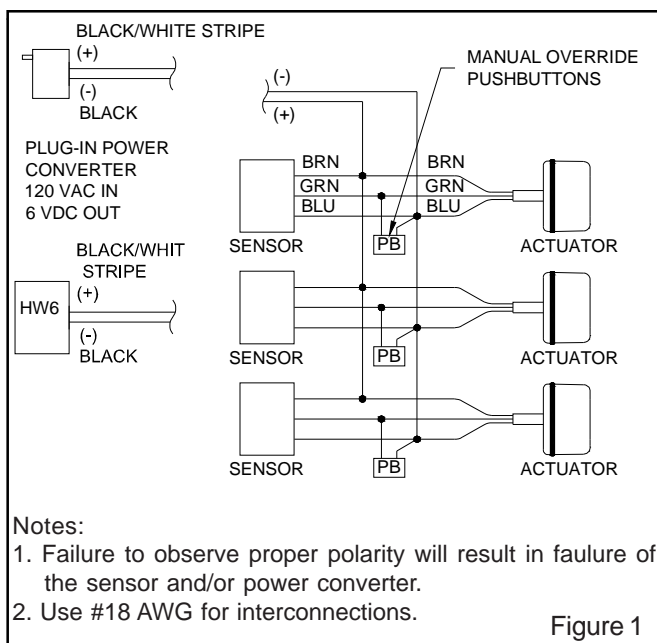

## PRIOR TO INSTALLATION

Prior to installing the Zurn Automatic Sensor-equipped Flushometer, install the items listed below as illustrated in Figures 1 through 3.

- 2-gang electrical box (4 x 4 x 2 1/8, use Steel City #52171-N box, and #52-C-18 device cover or equivalent for sensor with closet installs, or #52-C-14 reducing device or equivalent for sensor with urinal installs);
- Single-gang electrical outlet for plug-in power converter.
- Electrical wiring to the power converter outlet (120 VAC, 35 watts service required for each power converter used).
- Closet fixture.
- Zurn carrier system, Z1200 series or equal.

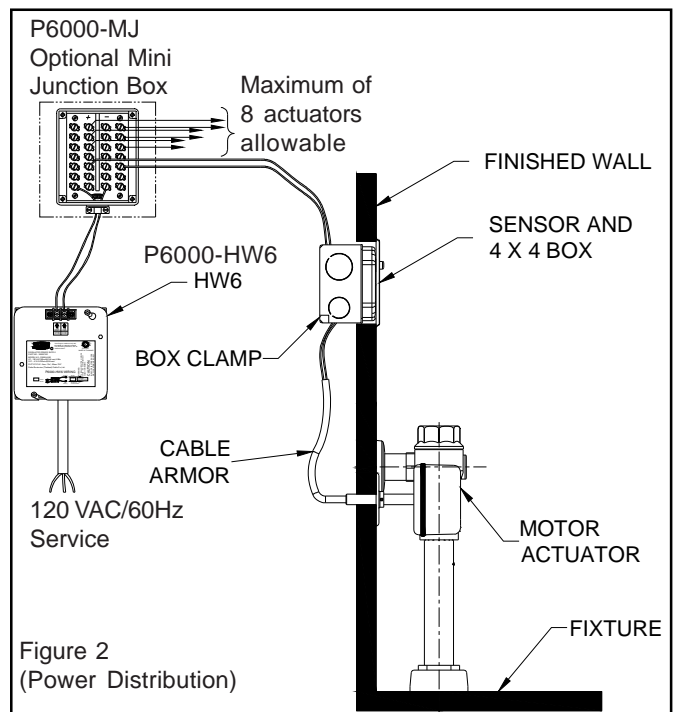

## Sensor Installation

**Closet Models:** Install plaster ring so screw holes are on left and right side of box. Trim tiles to allow screw holes in plaster ring to show.

**Urinal Models:** Install reducing cover so screw holes are on top and bottom side of box. Trim tiles to allow screw holes in plaster ring to show.

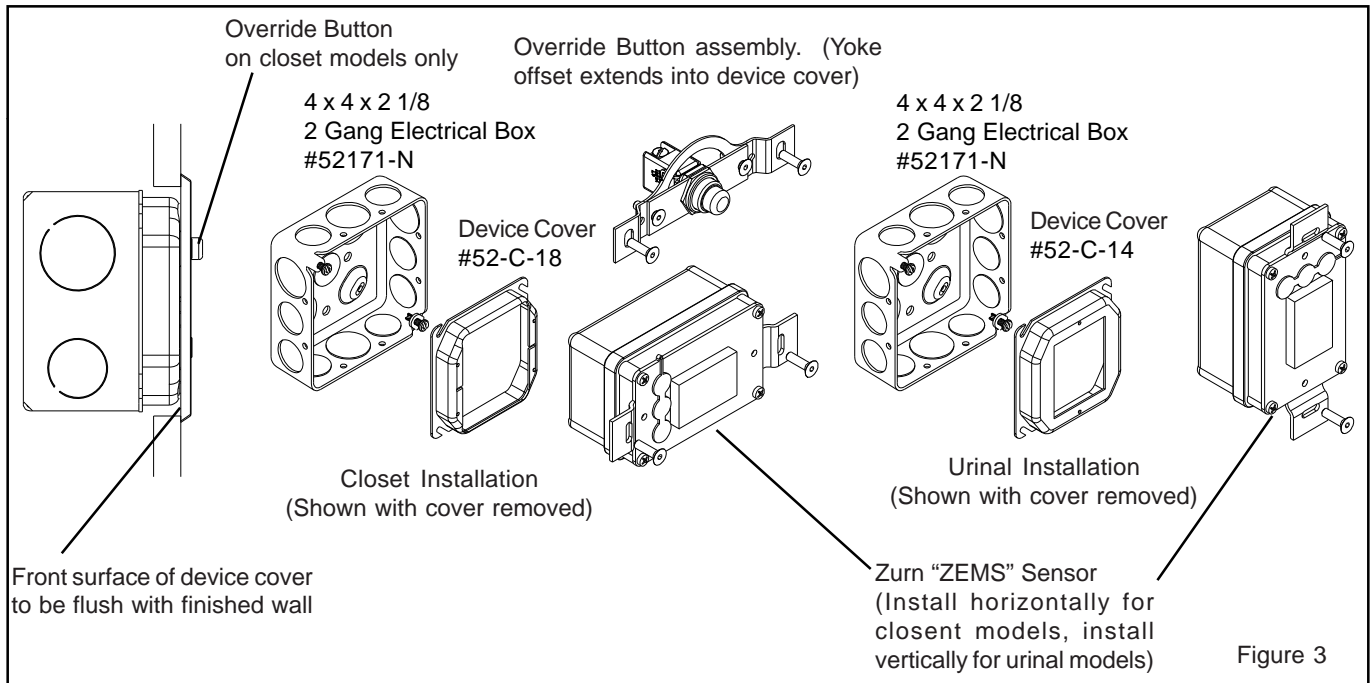

### STEP 1 – Locate sensor box

Locate sensor box in the wall according to model number as shown on pages 2 and 3.

### STEP 2 – Mount Automatic Sensor (Figure 3)

Install the Zurn Automatic Sensor into the 2-gang electrical box using two (2) long screws provided. Ensure that wires from sensor case point up for closet installs and point to the right for urinal installs. The rubber push caps will be on the left side of the sensor for closet and at the top for urinal (See Figures 4 and 4A). The sensor lens faces outward from the finished wall.

### STEP 3 – Mount Yoke and Override Button (Figure 4)

Install inner nut, bracket and sealing boot on threaded shaft of override push button. Mount bracket to yoke. Adjust the distance so that the override push button will protrude through the wall plate using the nuts on each side of bracket. Wire the override push button as per Figure 1. Mount the assembled yoke to the electrical box.

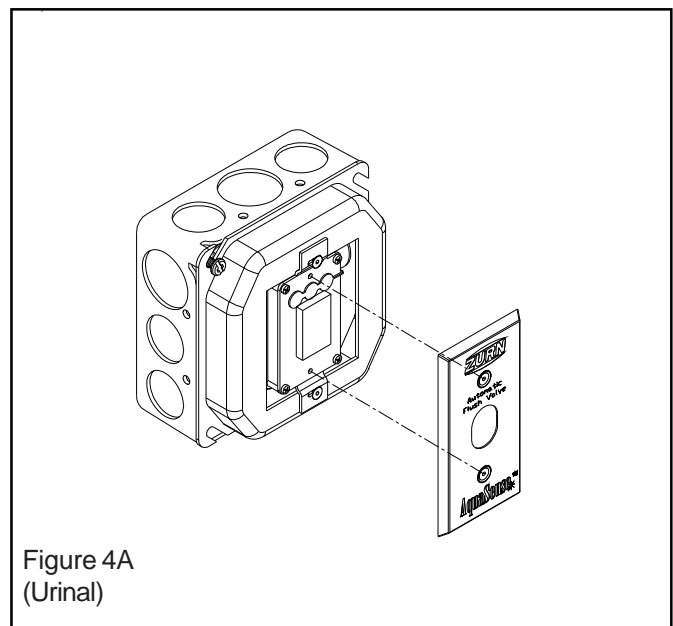
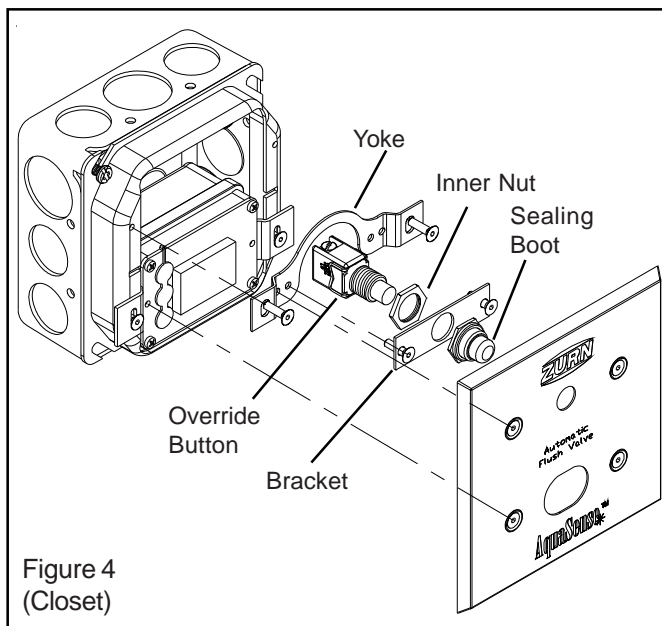

## Mechanical

The Metroflush® design is optimized to operate between 25 and 80 psi (172 to 552 kPa) of water pressure (running). The minimum pressure required for the valve to work properly is determined by the fixture selected. Please consult fixture manufacturer for water pressure requirements. Protect the chrome or special finish of this flushometer during installation. **Do not use toothed tools to install or service the valve as this will damage the finish.** Also, see “Care and Cleaning” section of this manual.

### Step 1

A. Install stop valve assembly using sweat solder adapter kit if applicable. Thread sealing compounds should be used on male NPT threads only.

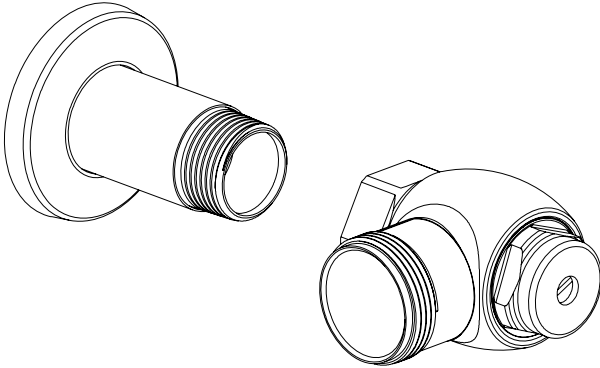

When all stops are connected to the water supply and water pressure is available, flush the supply piping to remove dirt, metal chips, etc., from system.

Figure 5

### Step 2

Before the valve is installed, open each stop fully for a brief time and catch the water in a two gallon or larger bucket. For multiple installations, start with the stop valve closest to the water supply and work toward the most remote valve.

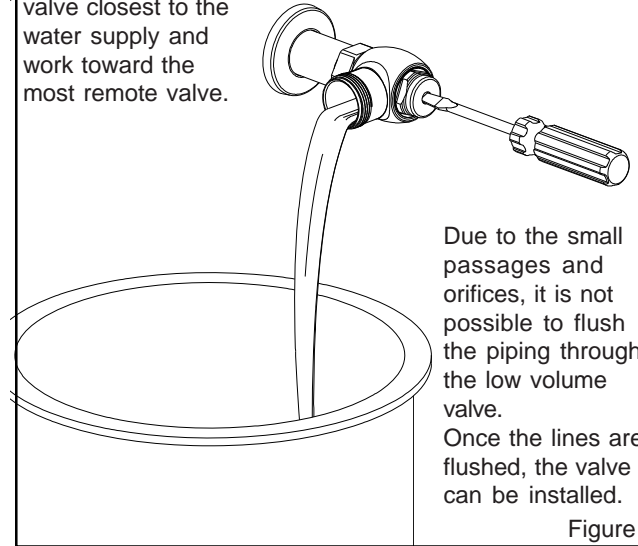

Due to the small passages and orifices, it is not possible to flush the piping through the low volume valve. Once the lines are flushed, the valve can be installed.

Figure 6

### Step 3

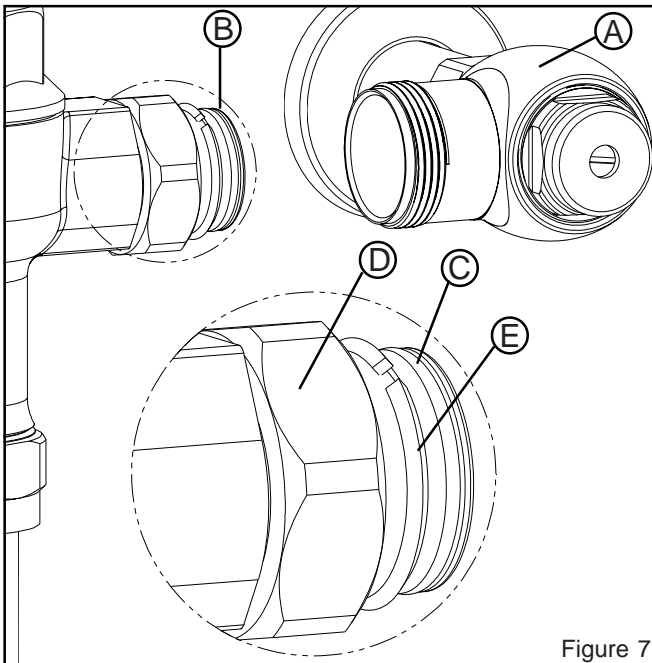

Figure 7

#### Attach Valve Body to Stop Valve

- 1.) Before the supply water is turned on, be sure all stop valves are closed off tight. The stop valves can be opened and closed by using the adjusting screw located at the center of the stop valve cap. Stop valve adjustments can only be made by using the adjusting screw. **It is not necessary to remove the stop valve cap when making adjustments. If for any reason it becomes necessary to remove the stop valve cap, be certain the water is shut off at the main supply valve.**
- 2.) Prior to inserting the flush valve tailpiece (B) into stop valve (A), be certain that the O-ring seal (C) is located in O-ring seal groove at the end of the tailpiece and that the locking nut (D) and locking snap ring (E) are located as shown. Care should be taken not to damage the O-ring when inserting the tailpiece into the stop valve. If lubrication is needed, wetting the O-ring with water will be sufficient.
- 3.) Insert the flush valve tailpiece (B) into the stop valve (A) and hand tighten the lock nut (D) to the stop valve. Level the entire unit.

**Install Vacuum Breaker Flush Connection**  
**Models ZEMS6200, ZEMS6200-2, ZEMS6200-3, ZEMS6201, and ZEMS6203**

Slide the tube nut (H), spud nut (G), slip gasket, rubber gasket and spud escutcheon over the vacuum breaker tube and insert tube into fixture spud. Hand tighten tube nut to valve body and hand tighten spud nut onto fixture spud. Adjust the valve assembly for plumb. Tighten fixture spud nut (G), vacuum breaker tube nut (H) and lock nut (D) (fig. 7) with a wrench.

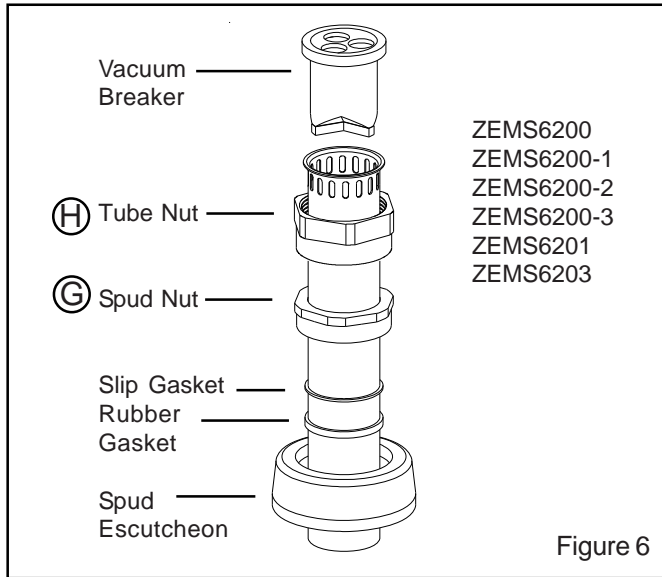

Figure 6

**Models ZEMS6240, ZEMS6242, ZEMS6252, ZEMS6290, ZEMS6295 and ZEMS6297 (Figure 9)**

**NOTE:** When cutting scored pipe, leave a minimum of 1-1/4" of scoring to ensure engagement with compression coupling.

Assemble pipe, elbows, couplings, slip washers, rubber gaskets and flanges as illustrated in Figure 7. Hand tighten all couplings. Once installation is completed, tighten all connections.

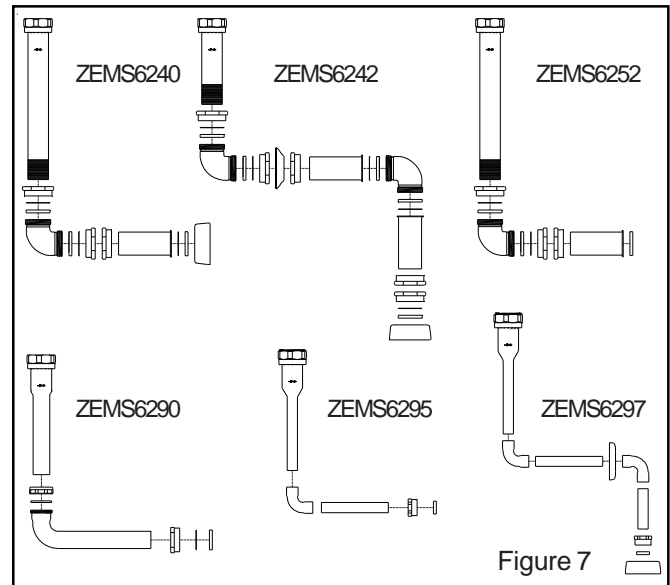

Figure 7

**Motor Actuator Installation (Figure 10)**

1. Drill 1-3/4" diameter hole per Figure 10.
2. Run "fish tape" from electrical box to 1-3/4" hole.
3. Install actuator escutcheon to the actuator pipe with setscrew toward actuator. Do not tighten setscrew at this time.
4. Pull actuator cable through hole with fish tape and back to sensor box. Secure armored cable to box with box clamp.
5. With escutcheon loose and handle port washer installed, push cable into wall. The actuator must be angled away from the valve body at this time until the actuator push rod clears the handle port flange. The actuator can now be mounted to the flush valve and tightened.
6. Push escutcheon back to wall and tighten setscrew.

**NOTE:** See Figure 2 for typical installation including optional mini junction box.

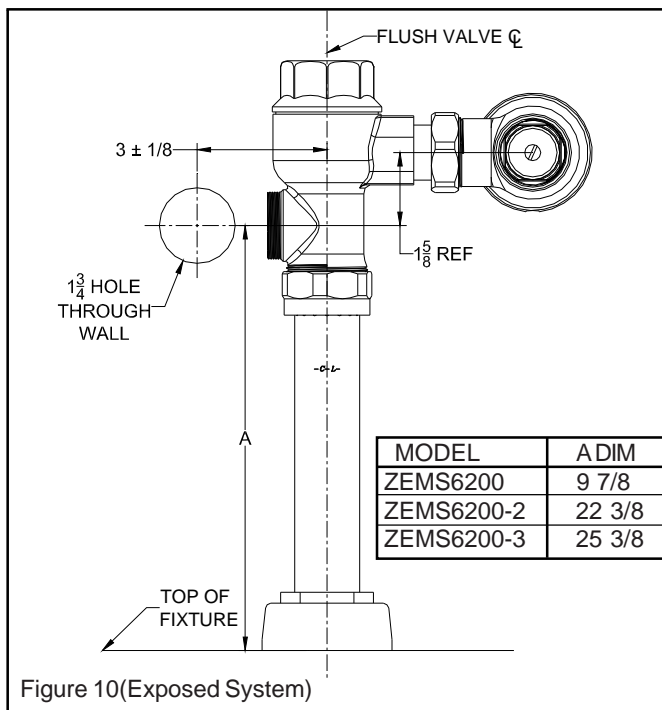

Figure 10(Exposed System)

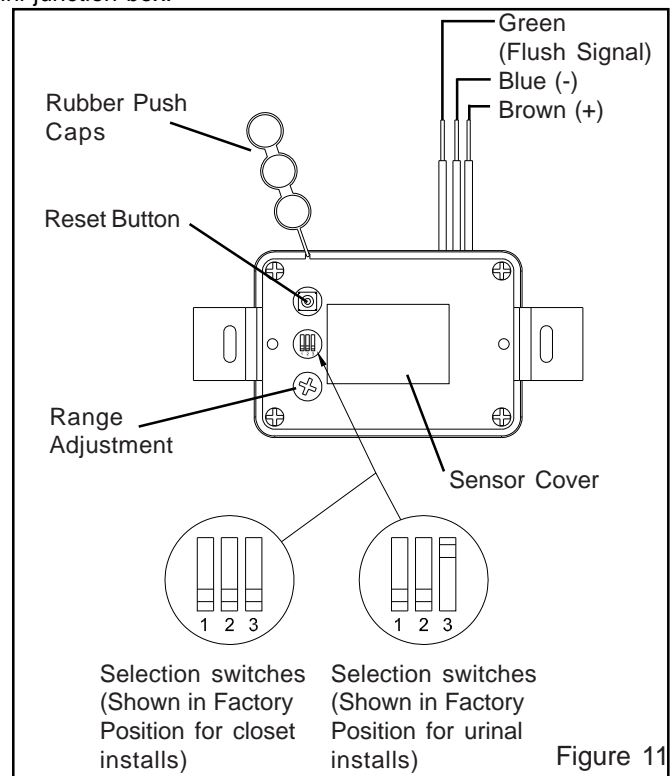

Figure 11

## Test and Adjustment (Figure 11)

(Also see "Sensor Features")

Zurn Automatic Sensors are preset at the factory and provide the user with selectable options as follows:

Switch 1 – Automatic Flush (Factory setting is on.)

Switch 2 – Red/Green LED (Factory setting is on.)

Switch 3 – Courtesy Flush (Factory setting is on for closet.)  
(Factory setting is off for urinal)

- **Red/Green LED** – With power applied the red light will illuminate when an object is detected. The green light will momentarily illuminate after the object has been detected for a minimum of 8 seconds then leaves. The green light indicates the flushing sequence.

- **Range Adjustments** – The Zurn Automatic Sensors are factory set to operate at a range of 50". This range should be satisfactory for most installations. If the range is too short (i.e., not detecting the user) or too long, adjust the range.

- **To Make A Range Adjustment** – Remove the rubber push caps. The range adjustment is shown in Figure 12. Using a small screwdriver, turn the range adjustment clockwise to increase range (maximum range is 60") or counter clockwise to decrease range (minimum range is 12").

**Note: This adjustment device is fragile. Be careful not to apply excess force.**

**IMPORTANT NOTE:** Excessive water flow creates noise, while too little flow will not satisfy the needs of the fixture. Proper adjustment is made when:

1. The plumbing fixture is cleansed after each flush without splashing water out from the lip.
2. A quiet flushing cycle is achieved.

After adjustment: Replace the Zurn stop cap screw cover.

## CARE AND CLEANING INSTRUCTIONS

**Do not** use abrasive or chemical cleaners to clean Flushometers and actuators as they may dull the luster and attack the chrome or special decorative finishes. Use only mild soap and water, then wipe dry with a clean cloth or towel.

While cleaning the bathroom tile, the Flushometer and actuator should be protected from splattering of cleaner. Acids and cleaning fluids can discolor or remove chrome plating.

## Seasonal use.

Valves use in installations subject to shut down because of cold and freezing conditions should be maintained in the following manner. After the main supply has been shut off and the water drained from the system, remove the stop valve cap and stop internals to allow the water to drain from the flush valve and supply line.

**CAUTION:** Range adjustment rotates only 1/2 turn total from min. to max. Do not exceed this or sensor will be damaged. Stand in front of the Zurn Automatic Sensor at the desired distance; the red light will illuminate when you are within range. Repeat adjustment procedure until the desired range is obtained.

## • Switch Settings (Figure 11)

The three switches control the following options. They can be activated or deactivated by means of the switches (down is on, up is off).

**Switch 1 – Automatic Flush** – The unit will automatically flush 24 hours after last user.

**Switch 2 – Red/Green LED** – When an object is detected the Red LED illuminates. The Green LED illuminates while flushing.

**Switch 3 – Courtesy Flush** – When an object has been detected for two seconds, the unit flushes and goes into the normal mode. This is repeatable after 90 seconds.

**NOTE:** After the options have been selected the reset button **must** be pushed for sensor to accept selections. Make sure rubber push caps are securely installed after making adjustments to protect sensor from moisture.

## STEP 11 – Adjust Control Stop (Figure 6)

Adjust the control stop to meet the flow rate required for proper cleaning of the fixture. Open control stop counterclockwise one half turn from closed position. Activate Flushometer simulating a user. Adjust the control stop after each flush until the rate of flow delivered properly cleanses the fixture.

## SENSOR FEATURES (See Step 10 for instructions.)

**1. Courtesy Flush:** The Sensor will provide a courtesy flush two seconds after a person is first detected. The courtesy flush removes any residue from the fixture. The main flush will occur when the user steps away from the fixture. The courtesy flush can be manually activated/deactivated at any time.

**2. Automatic 8-Hour Flush:** The sensor will provide an automatic flush 8 hours after the last user. The automatic flush can be manually activated/deactivated at any time.

**3. Adjustable Range:** The viewing distance is adjustable from 12" to 60".

**A. Indicator Lights:** The sensor unit has two operation lights, red and green. The red light is lit when an object is detected. The green is lit when the user leaves view of the sensor and unit is flushing. The indicator lights can be manually activated/deactivated at any time.

**B. Function Light:** Abnormal reflection detection function. If an object is in the viewing range for more than 30 minutes the red LED will blink. Range readjustment may be required.

## C. Maintenance Override (For Maintenance Purposes):

The sensor may be disabled for 10 minutes by placing a magnet on the sensor lens for 3 to 5 seconds. After 10 minutes the sensor will automatically resume functioning. Placing a magnet on the sensor for one second will restore normal operation and also provide a flush. These features are often desired for cleaning purposes.



# ZEMS6200 Metroflush Valve

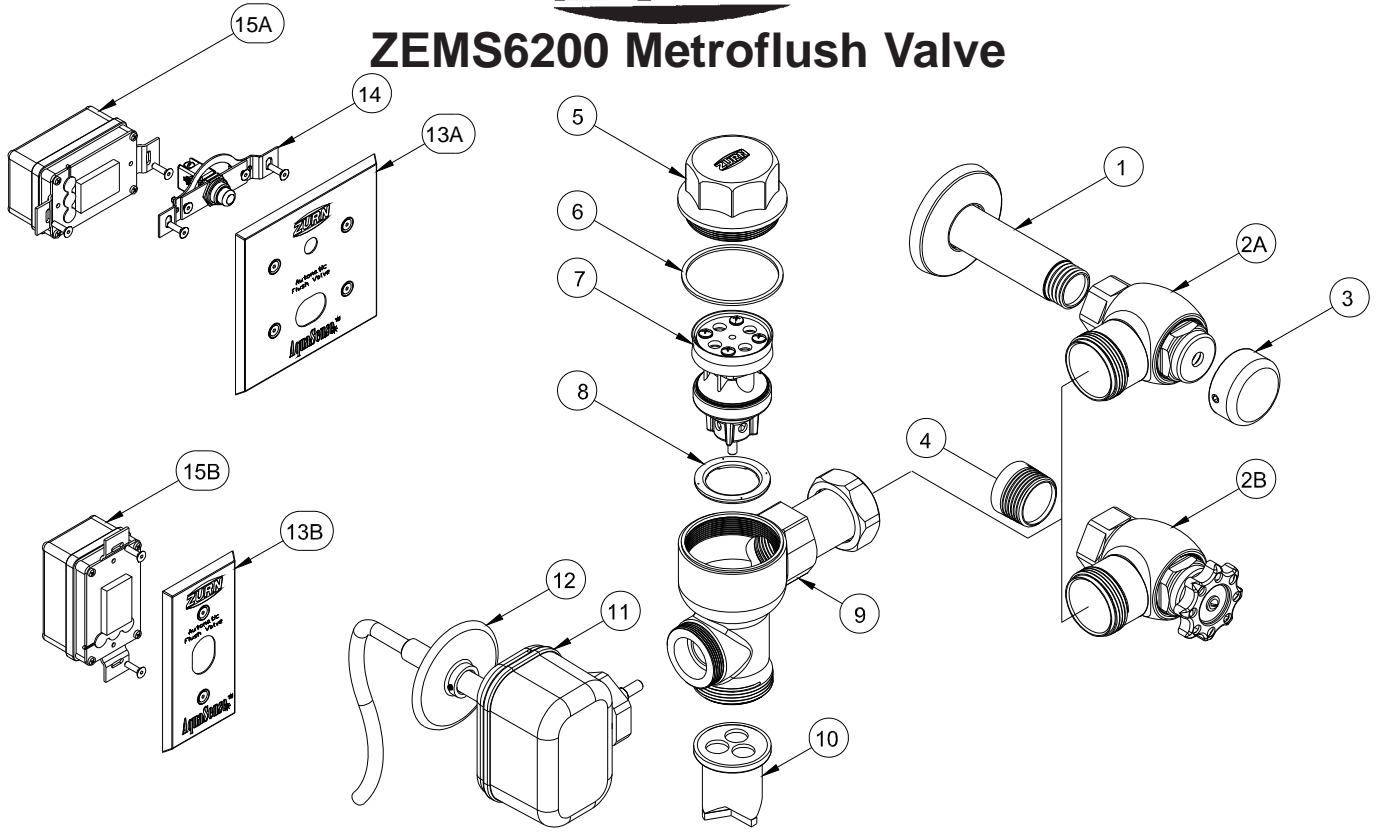

ZEMS6240

ZEMS6242

ZEMS6252

ZEMS6200  
ZEMS6200-1  
ZEMS6200-2  
ZEMS6200-3  
ZEMS6201  
ZEMS6203

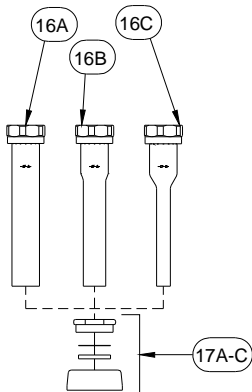
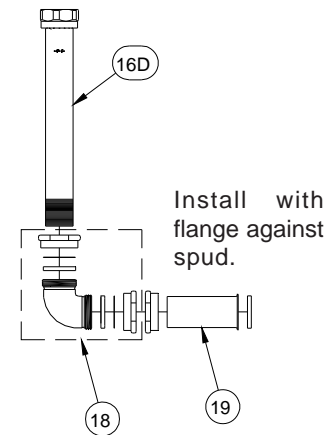
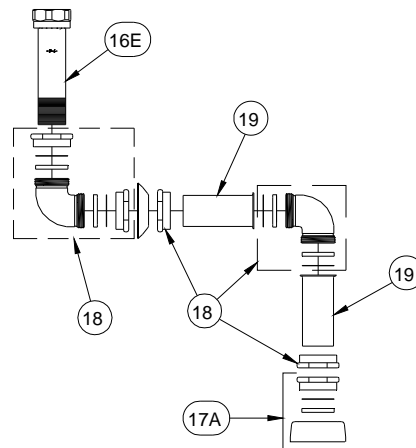
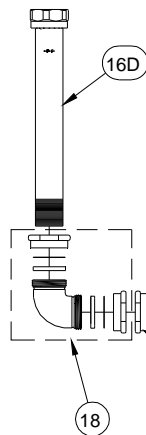

ZEMS6297

ZEMS6290

ZEMS6295

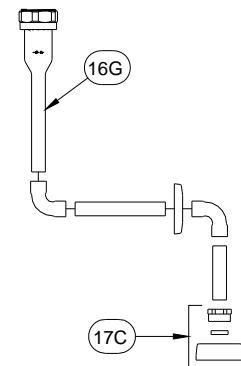
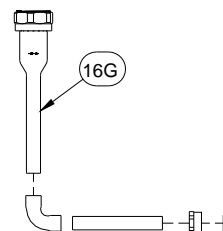
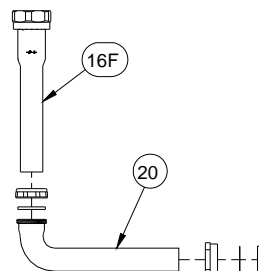

- |      |                 |   |      |                  |   |
|------|-----------------|---|------|------------------|---|
| 1.   | P6000-YB-YC     | Cast Wall Escutcheon & Solder Kit                     | 16B. | P6001-A-AA-CP    | Chrome Plated 1-1/4" X 8 1/2" Vacuum Breaker Assembly |
| 2A.  | P6000-D-SD      | Stop Assembly   | 16C. | P6003-A-AA-CP    | Chrome Plated 3/4" X 8 1/2" Vacuum Breaker Assembly   |
| 2B.  | P6000-D-WH      | Stop Assembly for Wheel Handle                        | 16D. | P6000-1-A-AA-RB  | Rough Brass 1-1/2" X 12 1/2" Vacuum Breaker Assembly  |
| 3.   | P6000-VC        | Vandal-Resistant Control Stop Cover                   | 16E. | P6000-A-AA-RB    | Rough Brass 1-1/2" X 5" Vacuum Breaker Assembly       |
| 4.   | P6000-YBA       | Sweat Solder Adapter                                  | 16F. | P6001-10-A-AA-RB | Rough Brass 1-1/4" X 10" Vacuum Breaker Assembly      |
| 5.   | P6200-LL        | Valve Body Cover                                      | 16G. | P6003-10-A-AA-RB | Rough Brass 3/4" X 10" Vacuum Breaker Assembly        |
| 6.   | P6200-L12       | Valve Body Cover Gasket                               | 17A. | P6000-H          | 1 1/2" Spud Coupling Assembly                         |
| 7.   | P6200-EC        | Closet Repair Kit (3.5 gpf)                           | 17B. | P6001-H          | 1 1/4" Spud Coupling Assembly                         |
|      | P6200-EU        | Urinal Repair Kit (1.5 gpf)                           | 17C. | P6003-H          | 3/4" Spud Coupling Assembly                           |
|      | P6200-EC-WS1    | Low Consumption Closet Kit (1.6 gpf)                  | 18A. | P6000-QE3-RB     | Rough Brass 1 1/2" Slip Elbow Assembly                |
|      | P6200-EU-WS1    | Low Consumption Urinal Kit (1.0 gpf)                  | 18B. | P6000-QE3-CP     | Chrome Plated 1 1/2" Slip Elbow Assembly              |
|      | P6200-EC-HET    | High Efficiency Closet Kit (1.28 gpf)                 | 19.  | <i>Varies</i>    | Chrome Plated slotless tube                           |
| 8.   | P6200-E14       | Main Seat   | 20.  | <i>Varies</i>    | Rough Brass Slip Elbow                                |
| 9.   | <i>Varies</i>   | Valve Body  |      |                  |   |
| 10.  | P6000-B         | Vacuum Breaker  |      |                  |   |
| 11.  | PEMS6000-HYM    | ZEMS Actuator   |      |                  |   |
| 12.  | PEMS6000-G      | ZEMS Escutcheon                                       |      |                  |   |
| 13A. | PESS6000-22     | ZEMS Closet Sensor Plate                              |      |                  |   |
| 13B. | PESS6000-22A    | ZEMS Urinal Sensor Plate                              |      |                  |   |
| 14.  | PESS6000-24     | ZEMS Closet Override Button                           |      |                  |   |
| 15A. | PESS6000-26     | ZEMS Closet Sensor                                    |      |                  |   |
| 15B. | PESS6000-26A    | ZEMS Urinal Sensor                                    |      |                  |   |
| 16A. | P6000-A-AA-CP   | Chrome Plated 1-1/2" X 8 1/2" Vacuum Breaker Assembly |      |                  |   |
|      | P6000-2-A-AA-CP | Chrome Plated 1-1/2" X 21" Vacuum Breaker Assembly    |      |                  |   |
|      | P6000-3-A-AA-CP | Chrome Plated 1-1/2" X 24" Vacuum Breaker Assembly    |      |                  |   |

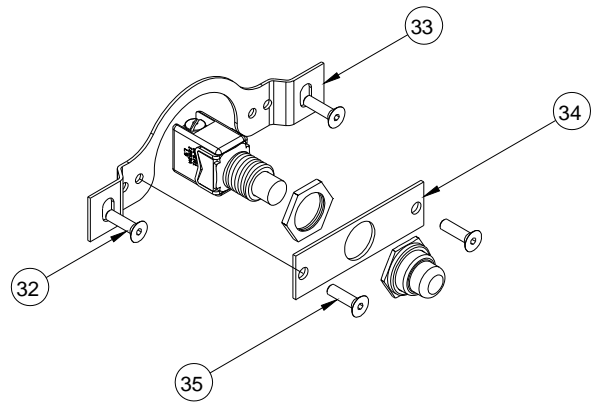
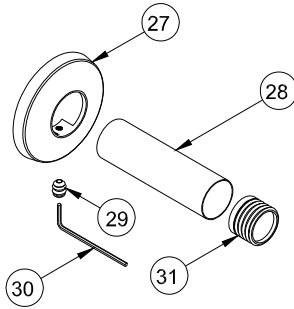
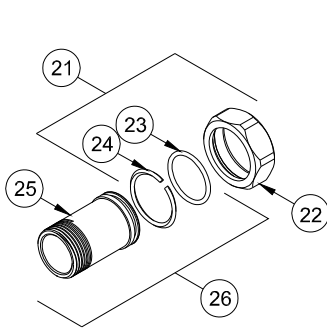

- |     |               |                               |     |               |                                   |
|-----|---------------|-------------------------------|-----|---------------|-----------------------------------|
| 21. | P6000-K       | Tailpiece Coupling Assembly   | 29. | P6000-VC-SS   | Setscrew for Cast Wall Escutcheon |
| 22. | P6000-C32     | Locking Nut                   | 30. | P6000-VC-W-VP | 5/64 Allen Wrench                 |
| 23. | P6000-C31     | Tailpiece O-Ring              | 31. | P6000-YB      | Sweat Solder Adapter              |
| 24. | P6000-C30     | Snap Ring                     | 32. | PESS6000-28   | Yoke Screw                        |
| 25. | <i>Varies</i> | Tailpiece                     | 33. | PESS6000-25   | Yoke                              |
| 26. | <i>Varies</i> | Adjustable Tailpiece Assembly | 34. | PESS6000-23   | Bracket                           |
| 27. | P6000-VC      | Cast Wall Escutcheon          | 35. | PESS6000-27   | Bracket Screw                     |
| 28. | P6000-YB-CVR  | Supply Cover Tube             |     |               |                                   |



ZURN INDUSTRIES, LLC. ♦ COMMERCIAL BRASS OPERATION ♦ 5900 ELWIN BUCHANAN DRIVE ♦ SANFORD NC 27330  
 Phone: 1-800-997-3876 ♦ Fax: 919-775-3541 ♦ World Wide Web: www.zurn.com  
 In Canada: ZURN INDUSTRIES LIMITED ♦ 3544 Nashua Drive ♦ Mississauga, Ontario L4V1L2 ♦ Phone: 905-405-8272 Fax: 905-405-1292

<b>Problem</b>	<b>Possible Cause</b>	<b>Corrective Action</b>
Valve will not operate.	1.) Stop valve is closed	1.) Open stop valve.
	2.) Supply valve is closed.	2.) Open supply valve.
	3) The electric wire(s) is not connected.	3) Connect the wires.
	4) The surface of the infrared cover is stained.	4) Clean the surface of the sensor cover.
	5) There is a reflective surface in front of the sensor.	5) Remove the reflective surface from in front of the sensor.
	6) The detection range is not adjusted properly.	6) Adjust the detection range.
	7) The infrared sensor or the actuator is out of order.	7) Contact distributor for replacement.
	8) Sensor fault	8) Replace sensor
	9) No power provided by power supply	9) Replace power supply
No red LED with target in view	1) The electric wire(s) is not connected or sensor fault.	1) Connect the wires.
Green LED illuminates with target removed, but does not	1) Electric wire fault.	1) Verify wire connections
	2) Sensor fault	2) Replace sensor
Insufficient volume of water to adequately siphon fixture	1.) Stop valve is not open enough.	1.) Open stop valve for desired volume of water.
	2.) Urinal piston installed in closet	2.) Replace urinal piston with proper closet piston.
	3.) Insufficient volume or pressure at supply.	3.) Consult fixture guide for minimum gallons per minute flow and running pressure for satisfactory performance.
Flush valve shuts off too quick.	1.) Damaged piston.	1.) Install new P6200-EC, P6200-EU replacement kit.
	2.) Enlarged by-pass orifice.	2.) Install new P6200-EC, P6200-EU replacement kit.
Valve is short flushing	1.) Enlarged by-pass orifice.	1.) Install new P6200-EC, P6200-EU replacement kit.
	2.) Urinal piston installed in closet	2.) Replace urinal piston with proper closet piston.
Valve is flushing too long or not shutting off.	1.) Trip mechanism not seating properly due to foreign material between trip mechanism and seat.	1.) Disassemble parts and rinse thoroughly.
	2.) By-pass orifice is plugged or partially plugged.	2.) Examine by-pass orifice and clean if necessary being certain not to enlarge orifice opening.
	3.) Line pressure is not adequate to force trip mechanism to seal.	3.) Pressure is inadequate or has dropped below minimum operating range. Steps should be taken to increase the line pressure.
Water splashes out of fixture/	1.) Supply volume is more than is necessary.	1.) Adjust downward on control stop.
	2.) Lime accumulation on vortex or spreader holes of fixture.	2.) Remove the lime build up.
Flush is not considered quiet.	1.) Control stop may not be adjusted for quiet operation.	1.) Adjust the control stop for quiet operation keeping in mind the fixture evacuation requirements.
	2.) Fixture may be contributing to noise.	2.) Check noise created by fixture by placing a cover over the bowl opening to separate valve noise from bowl noise. If it is determined the fixture is too noisy, consult with fixture manufacturer.
	3.) Piping system may be source of noise.	3.) High pressure in the system can sometimes be controlled by the stop valve. Other sources of noise may be the absence of air chamber and shock arrestors, loose pipes, improper size pipes, etc. In these cases the building engineer should be consulted.

#### Care of Chrome plated surfaces.

The suggested cleaning of chrome plated surfaces is simply to clean them with soap and water then dry. Commercial cleaning compounds are never recommended.

#### Seasonal use.

Valves used in installations subject to shut down because of cold and freezing conditions should be maintained in the following manner. After the main supply has been shut off and the water drained from the system, remove the stop valve cap and stop internals to allow the water to drain from the flush valve itself.

**ZURN INDUSTRIES, LLC. ♦ COMMERCIAL BRASS OPERATION ♦ 5900 ELWIN BUCHANAN DRIVE ♦ SANFORD NC 27330**

**Phone: 1-800-997-3876 ♦ Fax: 919-775-3541 ♦ World Wide Web: www.zurn.com**

**In Canada: ZURN INDUSTRIES LIMITED ♦ 3544 Nashua Drive ♦ Mississauga, Ontario L4V1L2 ♦ Phone: 905-405-8272 Fax: 905-405-1292**